



The Open Chemical Engineering Journal

Content list available at: <https://openchemicalengineeringjournal.com>



CASE REPORT

Challenges and Prospects of Converting Nigeria Illegal Refineries to Modular Refineries

Mamudu Angela^{1,*}, Okoro Emeka², Igwilo Kevin³, Olabode Oluwasanmi², Elehinafe Francis¹ and Odunlami Olayemi¹

¹Department of Chemical Engineering, Covenant University, Ota, Nigeria

²Department of Petroleum Engineering, Covenant University, Ota, Nigeria

³Department of Petroleum Engineering, Federal University of Technology, Owerri, Nigeria

Abstract: The sub-optimum conditions of Nigeria conventional refineries remains a drastic setback since all other industries are intertwined with its outputs. It is noted that amidst all other glaring contributing factors as listed in the study, insufficient large capital funds on the part of private investors and vandalization of pipelines seems to be conspicuous. The stolen crude oil got from the pipelines serve as the beginning point for illegal refining. Asides the issue of quality control of products, their sub-standard operation also affects Nigerians environmentally and economically. The more the Government invest time and resources to stop their operation; the more they spring up like mushrooms. This paper reflects the authors view on achieving a win-win scenario. The upgrading of existing illegal refineries at strategic locations within the country to standard modular refineries seems to be a more feasible and friendly approach. The issue of channeling of intermediate products can be solved through the introduction of clusters, where final products of one become raw material for the other. Intermediate products can also be channeled to Government owned conventional refineries for further processing. From analysis, it is deduced that overall design capacities from clusters have optimum effect on the intermediate environment in terms of meeting demand. Extensive operational training on crude oil refining will help buttress the point while Transfer of Knowledge from official vendors to Nigerian Engineers on how to fabricate modular refining units locally will also help to reduce overall cost.

Keyword: Nigeria, Modular, Illegal, Refineries, Crude oil, Enviroment.

Article History

Received: September 14, 2018

Revised: October 12, 2018

Accepted: October 19, 2018

1. INTRODUCTION

Crude oil as discovered in the oil field is a complex mixture of hydrocarbon compounds (Paraffin's/Naphthenes/Aromatics), non-hydrocarbon compounds (sulphur/nitrogen/oxygen), solids, water and different quantities of metallic compounds [1, 2].

In its unprocessed form, crude oil is generally not suitable for any industrial application, although light crude oil has earlier been used directly as a burner fuel to produce steam for the propulsion of sea going vessels. Petroleum refineries are therefore, put into place to convert or refine the unprocessed fluid into more useful products using both physical separation and chemical conversion processes [1, 3].

The physical separation processes separates the crude oil mixture without altering the chemical characteristics of its components. The chemical conversion processes which are either thermal or catalytic help to upgrade lower value fractions

into products better adapted to the markets, improve the characteristics of fuel or reduce the harmful impurities in petroleum fraction thereby protecting the natural environment during product manufacturing and utilization [4].

The importance of an operational refinery in any country cannot be underestimated as its products find applications in our everyday living. Although its primary product is the finished motor gasoline, diesel, kerosene, liquefied petroleum gas; petroleum coke, still gas, petrochemical products, residual fuel oil, asphalt and road oil are its by-products among so many others.

2. NIGERIA CONVENTIONAL REFINERIES

Although Nigeria presently has four conventional refineries (Kaduna, Warri, Old Port-Harcourt and the New Port-Harcourt) chiefly controlled by the Federal Government under the Nigerian National Petroleum Corporation (NNPC), none operate above 60 percent of its design capacity.

It is unfortunate that with a total of 445,000 bpd expected from these refineries, the country is presently still battling with scarcity of refined products as a result of its low refining state.

* Address correspondence to this author at the Department of Chemical Engineering, Covenant University, Ota, Nigeria; Tel: 08102419058; E-mail: angela.mamudu@covenantuniversity.edu.ng

Although a lot of reasons have been speculated to be the cause of this saddening situation, obvious ones include: inadequate funding and autonomy, bad maintenance culture, political instability, poor management, irregular feedstock supplies, non-implementation of the Petroleum Industry Bill (PIB), ineffective technical services department, vandalism of the pipelines, obsolete technologies and delayed turn around maintenance [5].

2.1. Private Investors

In an effort to encourage private investors into the petroleum downstream sector, preliminary licenses were issued to 26 private companies between year 2002 and 2004, to help build both refineries and petrochemical companies, but up to date, little success story has been recorded [6].

Although some made effort to commence, the companies experienced difficulties at different phases of the project and had to stop. The reasons given include: insufficient funds for capital project, political issues, government price regularization on products, un-conducive environment, power and security challenges and the unwillingness of the Federal Government to support local investors [7]. The operational private refineries in Nigeria include the Ogbelle Topping plant fully owned by the Niger Delta Petroleum Resources (NDPR) and the University of Port Harcourt modular topping refinery where both atmospheric and vacuum analysis can be carried out for the purpose of research and development.

2.2. Current Challenges

In an attempt to provide solutions to the above unfavorable scenario, the country is left with the following options: Establishment of more conventional refineries, legalization of illegal refineries, swapping of crude oil with refined products from other countries and setting up of modular refineries around the country.

The establishment of more conventional refineries by both the government and private investors seems to be moving on a snail speed. Large capital requirement and un-conducive environment serve as major hindrances. The full deregulation of the downstream petroleum sector and government assistance in raising funds will help in tackling this problem. The further establishment of more conventional refineries if these factors are not fully looked into might not yield significant output.

The legalization of illegal refineries brings mixed feelings among citizens as while some individuals fully support the idea, the others see it as a means of encouraging theft. Refineries can be characterized as illegal when the source of raw material (crude oil) are gotten through unofficial means or the mode of operations are sub-standard. Currently it is observed that the "bigger boys" now operate on sophisticated skid mounted automated refinery.

Generally problems associated with illegal refinery includes: pollution (air, land and water) [8], production of yield cuts with bad specifications, fires and explosion scenario, loss of capital infrastructures and profits for the Government, poor reputation of the country, community dispute and death of plants and animals. Although the government should not

legalize the illegal refinery operation, operational adjustment can be made to have a WIN-WIN situation.

Swapping of crude oil for refined products from other countries may serve as a temporary solution but definitely not a permanent one. There is also no direct measure of calculating the exact refined products for raw crude oil. It will also eventually lead to low employment rate within the citizens, bad reputation and more redundancy from the other established ones. This leaves the country with the most feasible option the establishment of modular refineries at strategic locations within the country.

2.3. The Modular Refinery Era

The concept modular refinery is not a practice that is relatively new. Although they were earlier used in the early forties, this concept later re-surfaced in the seventies when there were needs to solve problems associated with the conventional refinery [9].

A modular refinery is a conventional refinery constructed in a fragmented way [10] or simply a big refinery in miniature form [11, 12]. Globally this concept is applied successfully when crude oil and a ready market are available but low refining capacity is recorded. Further research shows that it can also be used when there is a need to reduce the transportation cost associated with the movement of crude oil from the field to refineries located in remote areas (Hogan, 1976). It also gives the option of setting up a refinery which can easily be hidden or taken down if the need arises [13]

J.S. Hogan [9] was the first to develop a one skid (12 feet wide, 45 feet long and 11 feet high) portable crude topping unit for the production of straight run gasoline, diesel oil and heavy fuel residue as shown in the Fig. (1) below. His intent was to put the plant into operation a day after arriving to its new location without the need of crane, concrete foundation or external power supply. The plant then had the ability to provide sufficient heat in an economic manner. He constructed an adjusting mechanism to overcome height limitation during transportation mode. Jack stands were also constructed at the bottom of the skids to help in moving the skids from one place to another. The idea of a modular topping unit on one skid with a jack stands was later phased out since cranes were currently available at most sites. There was also no need to crowd equipment on one skid; multiple skids were employed to provide for more room.

These modules which come in different sizes and capacities can be horizontal, vertical, single level or multi-level depending on the available plot space. They are always designed, fabricated and tested in a controlled shop environment before being transported to the project site for installation. They are either installed independently to create a small remote refinery or linked together in a cascading format to create a larger refining operation [10]. Over the years, they have become an effective solution for building refinery or gas processing facilities in remote places or offshore platforms where there is access to crude oil but low refining capacity.

2.4. Modular Refinery Configurations

The configuration of a modular refinery comes in different packages with increasing degree of sophistication [14], performing the three basic purposes of crude oil refining; separation, conversion and treatment. The different configurations include the following:

2.4.1. Topping (Atmospheric Distillation) Unit

A crude distillation unit as shown in Fig. (2) separates crude oil into different fractions or distillates based on their boiling points. It is mainly used for the production of diesel, kerosene, naphtha, liquefied petroleum gas while the residue serve as its by-products [14]. It is relatively cheap as compared to the full conventional refinery

2.4.2. Hydro-Skimming Unit

This is simply a gasoline train in addition to an atmospheric unit as shown in Fig. (3) The addition of a reformer and hydro-treating unit helps to produce high octane unleaded gasoline and LPG. It is also possible to add an Isomerization unit to boost the total octane rating of gasoline and produce more premium unleaded gasoline [14].

2.4.3. Vacuum Distillation Added Unit.

Below Fig. (4) is a modular vacuum distillation added unit. The process includes the addition of a second distillation tower to distil the residual from the atmospheric tower into vacuum gas oil and heavy vacuum residual oil under vacuum condition [14].

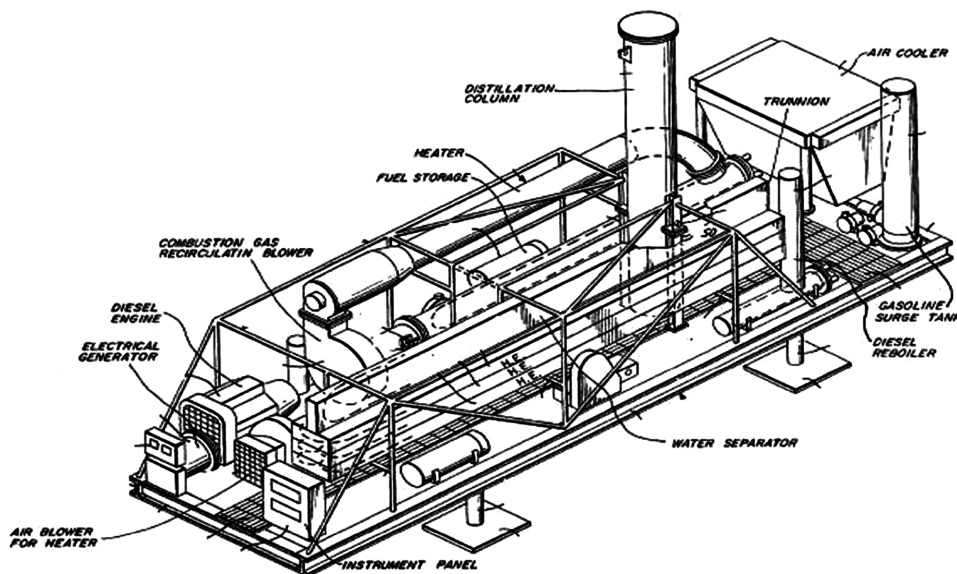

Fig. (1). First patented modular crude distillation refinery (Hogan, 1976).

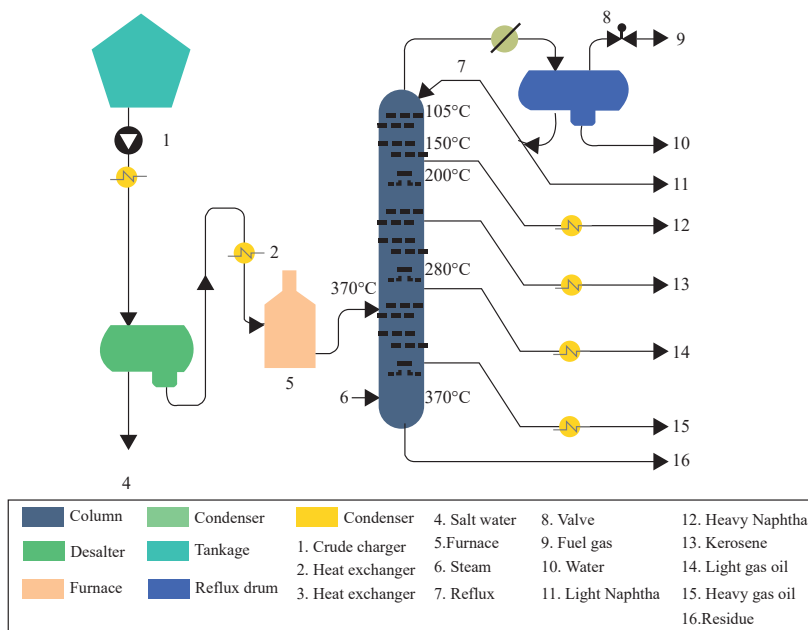

Fig. (2) . Atmospheric distillation unit. (Encyclopaedia Britannica, 1999).

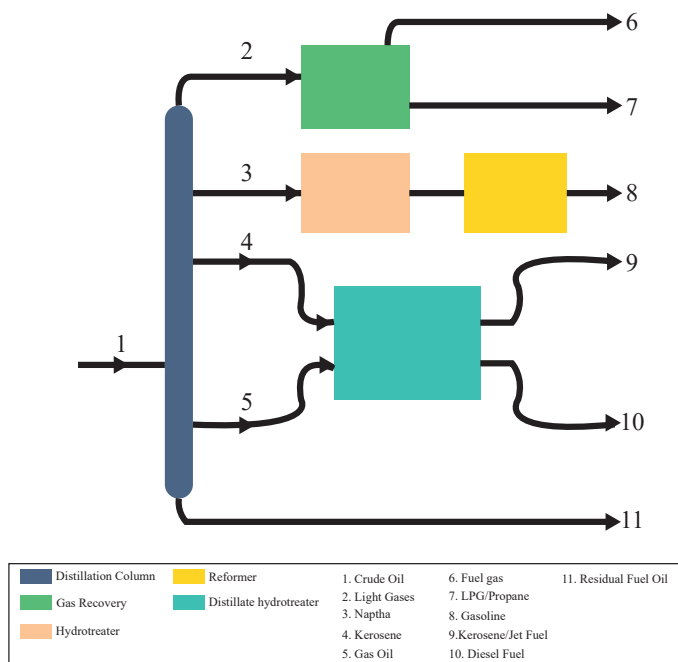

Fig. (3). Hydro-Skimming unit.(Encyclopaedia Britannica, 1999).

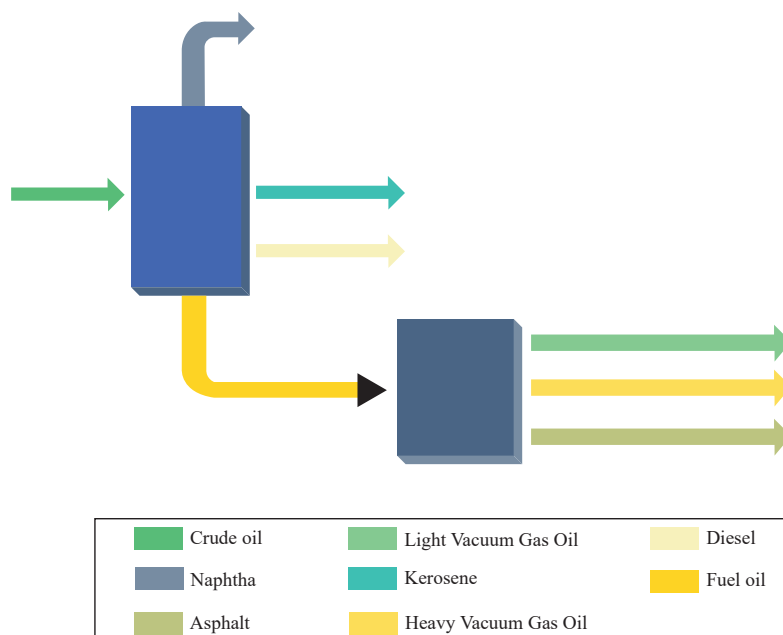

Fig. (4). Vacuum distillation added unit. (Cenam Energy, 2006).

2.4.4. Full Conversion Unit

This is also known as a full conventional refinery and includes the addition of a hydro-cracker and fluid catalytic cracking unit as shown in Fig. (5). It converts light and heavy gas oils to more valuable lower boiling point products. This significantly increases the yield making it a substantial contributor to refinery profitability [14].

2.5. Modular Refineries Locations

The following are areas where the different forms of modular crude refinery are currently being found [15].

- 2000 bpd (barrel per day) Modular Topping Units at

Megion Tyumen Region, Russia produces 16%, 36% and 48% of naphtha, diesel and residue respectively

- Two 150bpd Modular Topping Units at Strezhevoy, Siberia Russia produces 15%, 30% and 55% of naphtha, diesel and residue respectively
- Four 150bpd Modular Topping Units at Hides Gasfield, Papua processes gas condensate into 65%, 30% and 5% of naphtha, diesel and residue respectively
- 150bpd Modular Topping Units at Gobe Production Facility, New Guinea refines crude oil for the sole production of diesel
- 2000 bpd Modular Topping Unit at Eromanga

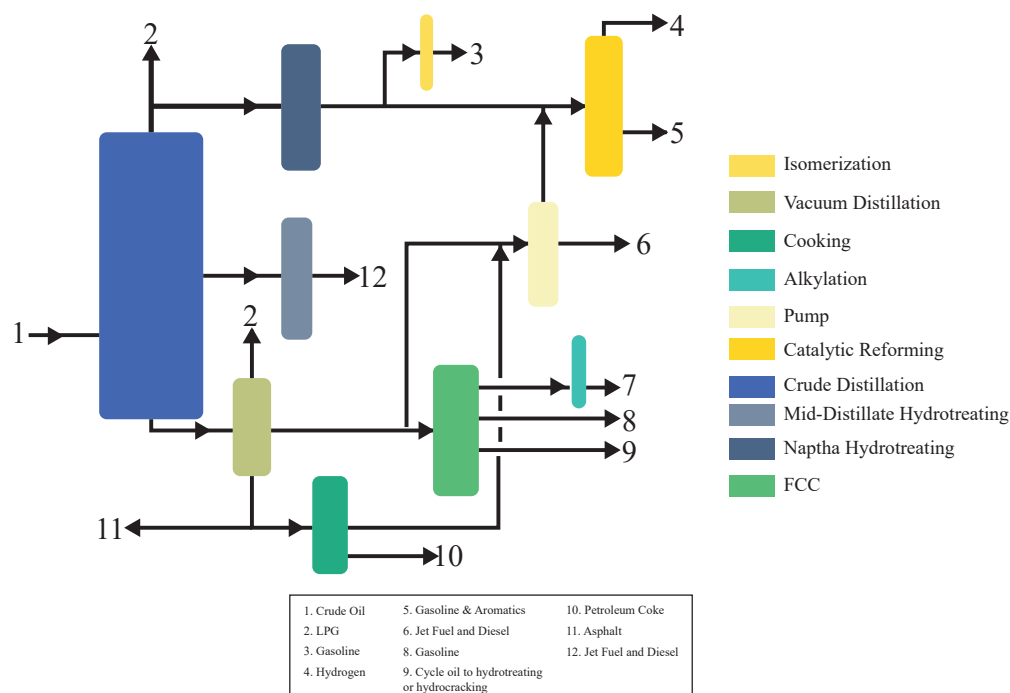

Fig. (5). Typical complex oil refinery. (Plant Process Equipment Incorporated).

- 150 bpd Modular Topping Unit located at Alice Spring Northern Territory, Australia produces 30%, 45% and 25% of naphtha, diesel and residue respectively

Others include (“A Barrel Full”, 2015):

- 500bpd Modular Atmospheric Distillation Unit, Australia
- 47000bpd Asyut Hydro-Skimming Refinery at Egypt
- 35000bpd Tanta Atmospheric Distillation Refinery at Cairo
- 7000bpd Wadi Feran Atmospheric Distillation Refinery located on the Red Sea in the Gulf of Suez
- 23000bpd “Societe Africaine de Raffinage” Hydro-skimming Refinery, Senegal
- 21000 bpd Sogara Hydro-Skimming Refinery Gabon
- 23000bpd Indeni Refinery Zambia has all units apart from the fluid catalytic cracking unit
- 21000bpd Coraf (Pointe Noire) Refinery Congo has all units apart from the fluid catalytic cracking unit
- 45000 Sonara /Limbe Hydro-Skimming Refinery located at Cameroun

Albeit the different modular configurations have successfully been applied in different areas, the modular topping (atmospheric) unit seems to be the prominent one in Nigeria since the country is relatively new to the idea. This leaves us with a great concern what do we do with the atmospheric residual oil and naphtha product since Nigeria does not currently have a ready-made market for them.

2.6. Clustering

To solve the problem of channelling of intermediate products, clusters of modular refinery schemes can be set at different locations within the country where final products of

one becomes the raw material of another one. The atmospheric residue and naphtha from the Modular Topping unit becomes the raw material for the vacuum added unit and hydro-skimming unit respectively. The other intermediate products can then be taken to Fluid Catalytic Cracking (FCC) clusters set at another location. It is also possible for intermediate products to be channeled to a Government owned conventional refineries for final processing.

From analysis, it can be deduced that little design capacities done in clusters have optimum effect on the intermediate environment in terms of meeting demand.

2.7. Prospects

In Nigeria, setting up modular refineries at strategic locations within the country will help in the following areas:

- Supporting the low performance of the existing refinery. A modular refinery will help to rapidly meet local demand with relatively low capital cost
- Eradicate the shortage of petroleum products across the country
- Drastically help to minimize our reliance on imported petroleum products
- Totally remove the need for subsidy
- Encourage private investors since start-up capital is low compared to a conventional refinery
- Remove the factor of vandalism as pipelines will not be laid across a wide area
- Ensure optimal use of our resource which has a multiplier effect on the economy

3. UPGRADING THE EXISTING ILLEGAL REFINERIES

In trying to eradicate completely the existence of the illegal

refineries, a bubble burst operation was carried out within the Niger Delta region between January and December 2012 by the Joint Task Force. 4349 illegal refineries, 1215 Cotonou boats, 187 tanker trucks, 178 fuel dumps and 5574 surface tanks were recorded to be destroyed while 1945 illegal oil bunkering suspects were arrested. The irony of it all is that the more the Government invests time and resources to stop their operation; the more they spring up like mushrooms.

Due to the environmental, economic, quality control and the hazardous effect associated with the illegal refineries and continuous cost of enforcing sanity in the region, there is need to upgrade the existing illegal refineries to a standard modular refinery since they operate on similar principles. This can be achieved through the following steps below:

- Training them on the principles behind conventional crude refining process
- Training them on how to operate a modular refinery
- Government entering into agreement with the vendors (modular refinery manufacturers) to transfer knowledge to Nigerians Engineers on how to fabricate modular refinery units

CONCLUSION

A significant way of reducing the impact of scarcity of petroleum products within Nigeria is to upgrade the existing illegal refining operations to standard modular ones. The efficiency of this approach will be realized if extensive operational training on crude oil refining is introduced and clusters are situated at strategic positions for channeling of intermediate products. Overall design capacities can also help in meeting local demand. Private individuals and investors will also be encouraged since a modular refinery is relatively cheaper compared to a full-grown conventional refinery.

CONSENT FOR PUBLICATION

Not applicable.

CONFLICT OF INTEREST

The authors declare no conflict of interest, financial or

otherwise.

ACKNOWLEDGEMENTS

The authors would like to thank Covenant University Centre for Research Innovation and Discovery (CUCRID), Ota, Nigeria for its support in making the publication of this research possible.

REFERENCES

- [1] S. Matar, and L.F. Hatch, *Chemistry of Petrochemical Process.*, 2nd ed Gulf Publishing Company, 2001, pp. 25-26.
- [2] A. Groysman, *Corrosion in Systems for Transportation and Storage of Petroleum Products and Biofuels.*, Springer: Dordrecht, 2014. [<http://dx.doi.org/10.1007/978-94-007-7884-9>]
- [3] J.G. Speight, *The Chemistry and Technology of Petroleum.*, 4th ed CRC Press: New York, 2006.
- [4] P. Leprince, *Petroleum Refining Conversion Processes.*, 3rd ed Institut Francais du Petrole Publications, 2000.
- [5] A. Ogedegbe, "The Nigerian Petroleum Refineries: History, Problems and Possible Solutions", Lecture delivered at the Centre for Gas", In: *Refining and Petrochemical Engineering Institute of Petroleum Studies, University of Port Harcourt*, 2009.
- [6] The Tide, *Where Are the Private Refineries*. Available at <http://www.thetidenewsonline.com/2011/08/31/where-are-the-private-refineries/> [Accessed 30 Sep. 2015].
- [7] The Guardian, *Stillbirth of Nigeria's Private Refineries*. Available at <http://guardian.ng/energy/stillbirth-of-nigerias-private-refineries/>
- [8] O.A. Odunlami, F.B. Elehinafe, A.A. Pearl, O.G. Abatan, and A.O. Mamudu, "Assessment of carbon monoxide emission from different brands of split air-conditioners", *Int. J. Mech. Eng. Tech.*, vol. 9, no. 9, pp. 655-662, 2018.
- [9] J.S. Hogan, "Mobile Refinery", US Patent 3953298A, 1974.May 06,1974
- [10] K.B. Brown, B.L. Maxwell, R.V. Rick, and M.D. Shumway, Modular Oil Refinery, U.S. Patent WO 2003031012A1, April 17, 2003.
- [11] G.J. Igwe, *Modular refineries will address perennial shortage of petroleum products.*. Available at <http://businessnews.com.ng/2014/09/08/modular-refineries-will-address-perennialshortage-petroleum-products-igwe/> Accessed 2 Oct.2015
- [12] O.A. Mamudu, G.J. Igwe, and E. Okonkwo, "Process Design Evaluation of an Optimum Modular Topping Refinery for Nigeria Crude Oil using HYSYS Software", *Society of Petroleum Engineers(SPE) Nigeria Annual International Conference and Exhibition*, 2016 [<http://dx.doi.org/10.2118/184342-MS>]
- [13] J.W. Duncan, and L. Knox, "Overland Petroleum Processor 1991", US Patent 4983259, 1991. January 04,
- [14] C. Energy, *The Case for Modular Mini-Refineries*. Available at <https://cenamenergypartners.files.wordpress.com/2012/06/modular-refineries.pdf> Accessed 29 Sep. 2015
- [15] Mini-refinery, Available at <http://www.minirefinery.com> Accessed 29 Sep. 2015